



Backer Rod Mfg. Inc.

www.backerrod.com

Customer Service (800) 595 2950



UL System No. FF-S-0012

September 14, 2001

Assembly Rating – 2 Hr

Joint Width – 3/4 In. Maximum

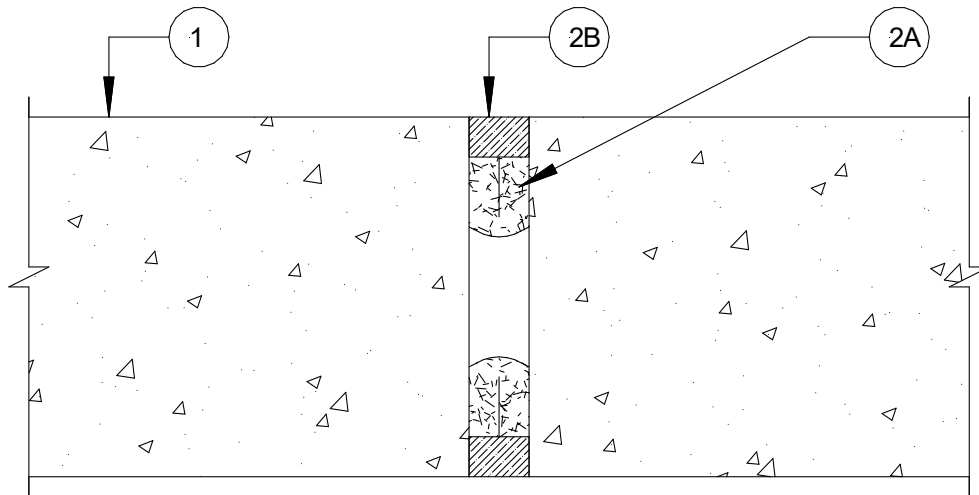

1. **Floor Assembly** – Min 4 ½ in. thick reinforced lightweight or normal weight (100 – 150 pcf) structural concrete.
2. **Joint System** – Max width of the joint is ¾ in. The joint system shall consist of the following:
 - A. **Forming Material*** - For joint openings up to ½ in. in width, the forming material shall be a min of 3/8 in. thick. For joint openings up to ¾ in. in width, the forming materials shall be a min of 1/2 in. thick. A nom 2 in. width of forming material shall be folded in half and firmly packed into joint opening as a permanent form. Forming material to be recessed from each surface of floor as required to accommodate the required thickness of fill material.
BACKER ROD MFG. INC. – ULTRA BLOCK®
 - B. **Fill, Void or Cavity Material*** - Min ½ in. thickness of fill material applied within the joint, flush with each surface of floor.
RHODIA SILICONES – FR-71

* Indicates such products shall bear the UL or cUL Certification Mark for jurisdictions employing the UL or cUL Certification (such as Canada), respectively.