



# Backer Rod Mfg. Inc.

[www.backerrod.com](http://www.backerrod.com)  
Customer Service (800) 595 2950



## UL System No. FF-S-1009

November 18, 2008

Assembly Rating – 2 Hr

Joint Width – 4 In. Maximum

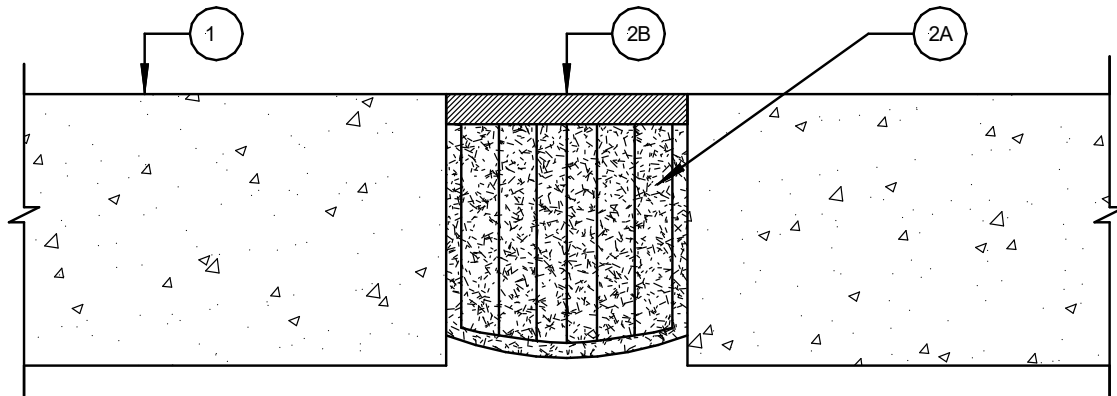

1. **Floor Assembly** – Min 4 ½ in. (114 mm) thick reinforced lightweight or normal weight (100 – 150 pcf or 1600-2400 kg/m<sup>3</sup>) structural concrete.
2. **Joint System** – Max width of the joint is 4 in. (102 mm). The joint system shall consist of the following:
  - A. **Forming Material\*** - Max 11 in. (279 mm) width of forming material shall be folded in half and packed into joint opening as a permanent form. Forming material to be recessed from top surface of the floor to accommodate the required thickness of fill material.  
**BACKER ROD MFG. INC. – ULTRA BLOCK®**
  - B. **Fill, Void or Cavity Material\*** - Min ½ in. (13 mm) thickness of fill material applied within the joint, flush with top surface of the floor.  
**MOMENTIVE PERFORMANCE MATERIALS – PENSIL 300 or PENSIL 300 S/L SEALANTS**  
**SPECIFIED TECHNOLOGIES INC – PENSIL 300, PENSIL 300 S/L, SPECSEAL SERIES SIL300 or SPECSEAL SERIES SIL300SL SEALANTS**

\* Indicates such products shall bear the UL or cUL Certification Mark for jurisdictions employing the UL or cUL Certification (such as Canada), respectively.